

RSFT-63EM

60 MAGICLOTUS

SANDWICHES PLATE ABOVE GRIDLDE

Sandwiches plate above electric gridde -
plate cm. 29x40 (ATTENTION: DEPTH
MACHINE +cm.10)



Construction - Fabricated using CrNi 18/10 AISI 304 grade Stainless Steel Scotch-Brite Satin polish Finish, chromed details. Model - Professional electric hot plate for sandwiches to be mounted above a electric griddle. On the surface of the plate there is a removable sheet made of no-adherent food teflon, resistant to high temperatures. Control thermostat 50-230 ° C. Equipped with ergonomic heat-insulated handle, 2 adjustable springs allow a fluid movement and a perfect balance in every position, for more security. Maintenance - All serviceable parts are accessible by the easy removal of superior panel. Fittings - mounting bracket for Magiclotus 60.



ITALIAN CULINARY ART

The pictures are purely representative. The manufacturer reserves the right to modify the technical data and models without previous notice.

RSFT-63EM

60 MAGICLOTUS

SANDWICHES PLATE ABOVE GRIDLDE

RSFT-63EM

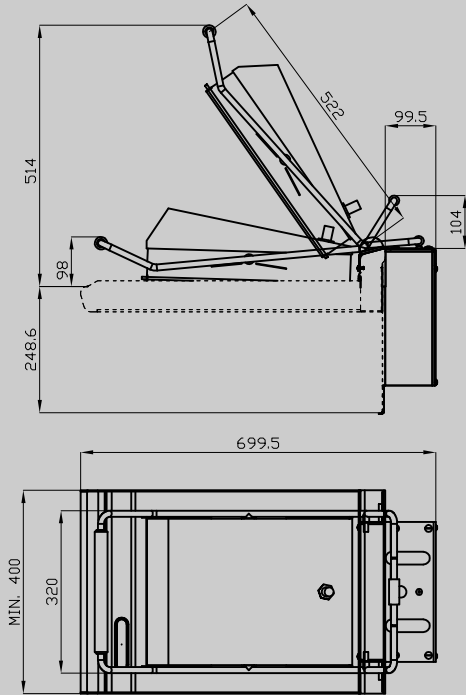

RSFT-73EM

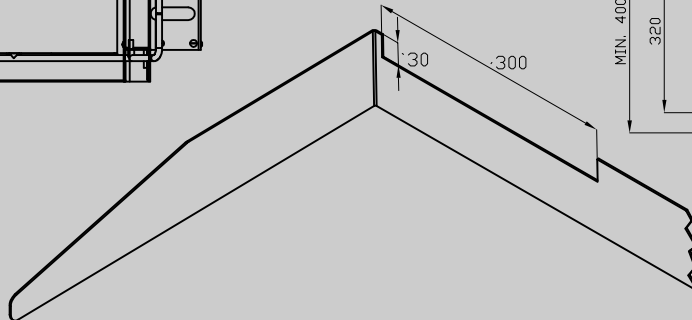
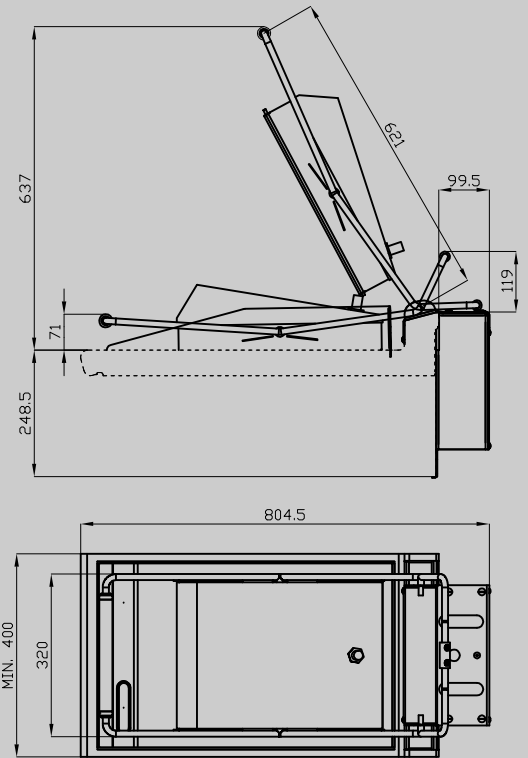

| | | | | | |
|---|------------|--|---|-----------------------|--|
| A | Data plate | | B | Electrical connection | |
|---|------------|--|---|-----------------------|--|

MODEL: RSFT-63EM
DIMENSIONS: cm. 32x 61x 41h
ELECTRIC POWER: 2,9 KW
VOLTAGE: 230V~
FREQUENCY: 50/60 Hz



kg: 20
m³: 0.209
mm: 430x770x630

BUY LOTUS BUY ITALY

The pictures are purely representative. The manufacturer reserves the right to modify the technical data and models without previous notice.



LOTUS S.P.A. Via Calmaor, 46
31020 San Vendemiano(TV) - Italy
Tel. + 39 0438 778020 / 778468
Fax + 39 0438 778277
www.lotuscookers.it - lotus@lotuscookers.it