

# CWT-68G

60 MAGICLOTUS

GAS CHARCOAL GRILL - TOP



Lavastone grill gas N. 2 Stainless steel grill  
cm. 38x42,5 - 2 cooking areas



Construction - Fabricated using CrNi 18/10 AISI 304 grade Stainless Steel Scotch-Brite Satin polish Finish, incorporating 1mm thick worktop, rounded edges, chromed details and rear splash back. Knobs with waterproof grades IPX5. Model - Professional Gas Charcoal Grill. Grill container for holding Lava Rock over burners. Burners with Piezoelectric ignition and pilot light, thermocouple safety valves, Removable liquid containers. Maintenance - All serviceable parts are accessible by the easy removal of front control panel. Fittings - Appliance is supplied with both LPG and Natural Gas conversion jets and adjustable feet.



ITALIAN CULINARY ART

The pictures are purely representative. The manufacturer reserves the right to modify the technical data and models without previous notice.

# CWT-68G

60 MAGICLOTUS

GAS CHARCOAL GRILL - TOP

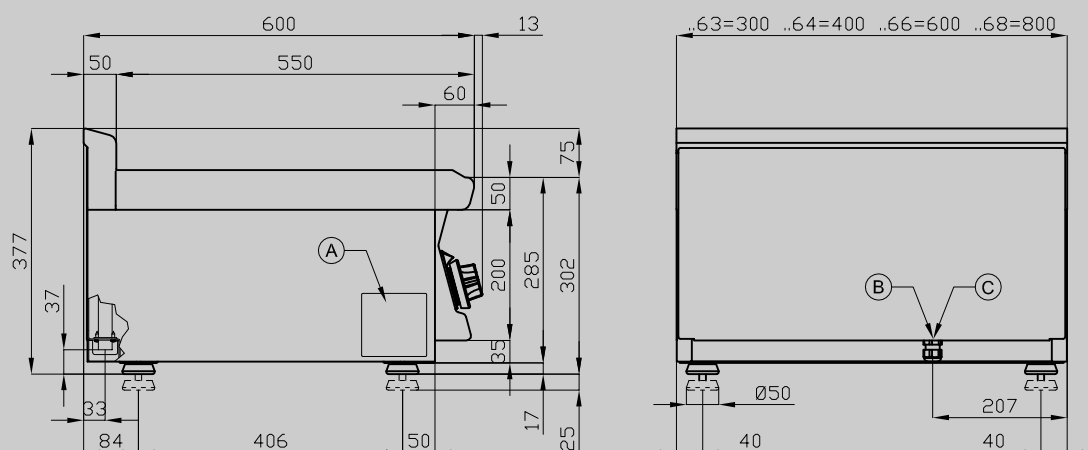

A	Data plate	C	Gas connection	ISO 7-1 1/2" M
---	------------	---	----------------	----------------

MODEL: CWT-68G  
DIMENSIONS: cm. 80x 60x 28h  
GAS POWER: 11,6 kW / 9.976 kcal/h  
GAS TYPE: Natural Gas / LPG



kg: 62  
m<sup>3</sup>: 0.372  
mm: 830x690x650

BUY LOTUS BUY ITALY

The pictures are purely representative. The manufacturer reserves the right to modify the technical data and models without previous notice.



LOTUS S.P.A. Via Calmaor, 46  
31020 San Vendemiano (TV) - Italy  
Tel. + 39 0438 778020 / 778468  
Fax + 39 0438 778277  
www.lotuscookers.it - lotus@lotuscookers.it