

# CWKT-68ET

60 MAGICLOTUS

ELECTRIC GRILL - TOP



CONTACT Grill threephase - Stainless steel  
grill cm. 55x35



Construction - Fabricated using CrNi 18/10 AISI 304 grade Stainless Steel Scotch-Brite Satin polish Finish, incorporating 1mm thick worktop, rounded edges, chromed details and rear splash back. Knobs with waterproof grades IPX5. Model - Professional Electric Grill. Fitted with water compartment and special reflective system to optimise heat, Removable liquid containers. Contact model for direct cooking above the rotatable heating element in stainless steel. Maintenance - All serviceable parts are accessible by the easy removal of front control panel. Fittings - Appliance is supplied with adjustable feet.



ITALIAN CULINARY ART

The pictures are purely representative. The manufacturer reserves the right to modify the technical data and models without previous notice.

# CWKT-68ET

60 MAGICLOTUS

ELECTRIC GRIILL - TOP



View 3D

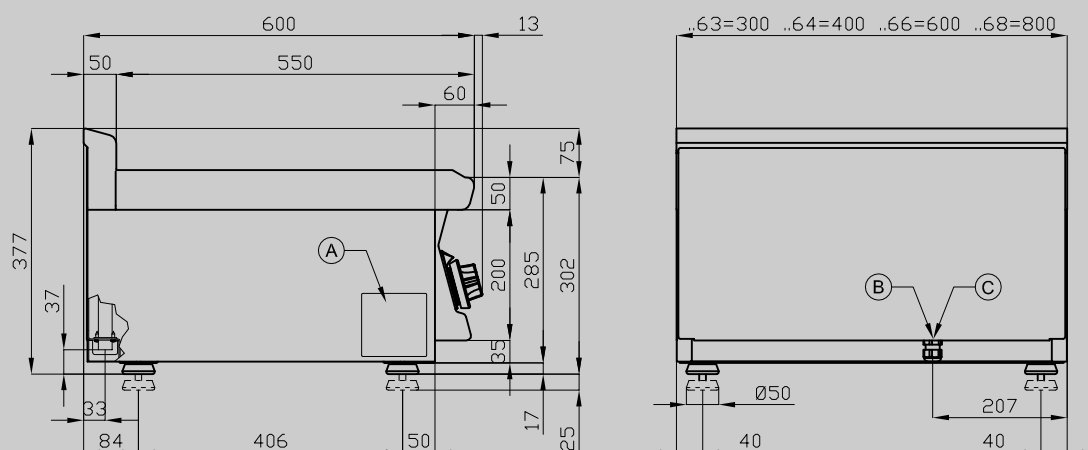

A	Data plate	B	Electrical connection
---	------------	---	-----------------------

MODEL: CWKT-68ET  
DIMENSIONS: cm. 80x 60x 28h  
ELECTRIC POWER: 6,72 kW  
VOLTAGE: 400V~3N  
FREQUENCY: 50/60 Hz



kg: 50  
m<sup>3</sup>: 0.372  
mm: 830x690x650

BUY LOTUS BUY ITALY

The pictures are purely representative. The manufacturer reserves the right to modify the technical data and models without previous notice.



LOTUS S.P.A. Via Calmaor, 46  
31020 San Vendemiano(TV) - Italy  
Tel. + 39 0438 778020 / 778468  
Fax + 39 0438 778277  
www.lotuscookers.it - lotus@lotuscookers.it