

FTLRT-68ET

60 MAGICLOTUS

ELECTRIC GRIDDLE - TOP



Electric Fry-top 1/2 grooved + 1/2 smooth,
plate cm.79,5x45 - 2 cooking areas



Construction - Fabricated using CrNi 18/10 AISI 304 grade Stainless Steel Scotch-Brite Satin polish Finish, incorporating 2,5mm thick worktop, rounded edges, chromed details and rear splash back. Knobs with waterproof grades IPX5. Model - Professional Electric Griddle, Smooth, Ribbed or 50 / 50, Normal or Chrome. Normal Plate in FE430B Steel and Chrome in FE510C Steel. Double thermostat, operating and safety. High durability and rapid heat up. 50 - 300degC control, Removable liquid containers. Maintenance - All serviceable parts are accessible by the easy removal of front control panel. Fittings - Appliance is supplied with adjustable feet.



ITALIAN CULINARY ART

The pictures are purely representative. The manufacturer reserves the right to modify the technical data and models without previous notice.

FTLRT-68ET

60 MAGICLOTUS

ELECTRIC GRIDDLE - TOP

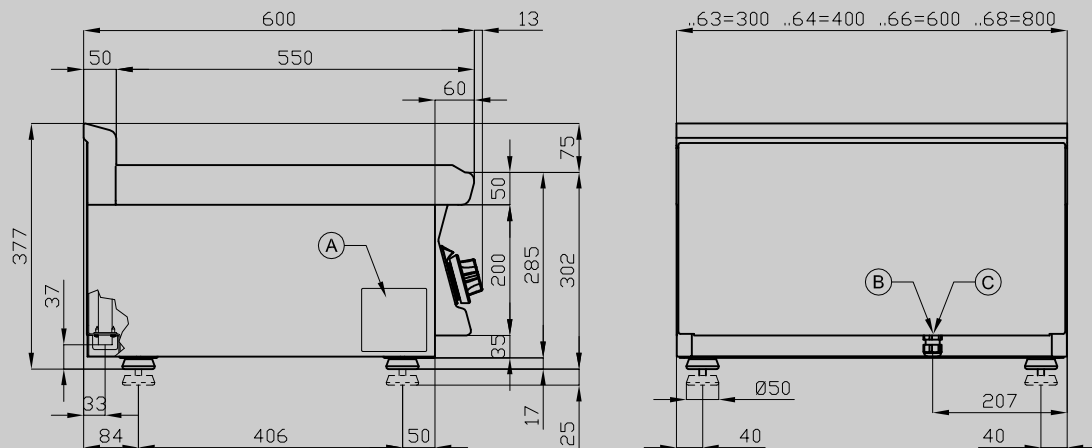

A	Data plate	B	Electrical connection
---	------------	---	-----------------------

MODEL: FTLRT-68ET
DIMENSIONS: cm. 80x 60x 28h
ELECTRIC POWER: 9 kW
VOLTAGE: 400V~3N / 230V~3
FREQUENCY: 50/60 Hz



kg: 81
m³: 0.372
mm: 830x690x650

BUY LOTUS BUY ITALY

The pictures are purely representative. The manufacturer reserves the right to modify the technical data and models without previous notice.



LOTUS S.P.A. Via Calmaor, 46
31020 San Vendemiano(TV) - Italy
Tel. + 39 0438 778020 / 778468
Fax + 39 0438 778277
www.lotuscookers.it - lotus@lotuscookers.it