

# PCCT-66ET

60 MAGICLOTUS

ELECTRIC BOILING UNIT - TOP



Ceramic glass boiling unit - n. 4 zones - glass  
cm.55x47



Construction -Fabricated using CrNi 18/10 AISI 304 grade Stainless Steel Scotch-Brite Satin polish Finish, incorporating 1mm thick worktop, rounded edges, chromed details and rear splash back. Knobs with waterproof grades IPX5. Model - Professional Electric Boiling Hob. Cast Iron round hot plates with steel border seals, seven position switch and temperature limiter. Ceramic glass tops with radiant heat hot plates and warning lights for residual heat. Maintenance - All serviceable parts are accessible by the easy removal of front control panel. Fittings - Appliance is supplied with adjustable feet.

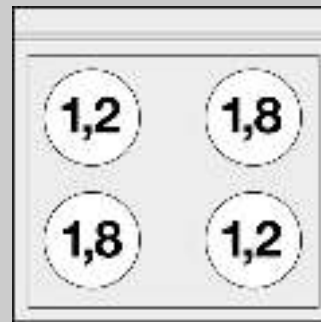

ITALIAN CULINARY ART

The pictures are purely representative. The manufacturer reserves the right to modify the technical data and models without previous notice.

# PCCT-66ET

60 MAGICLOTUS

ELECTRIC BOILING UNIT - TOP

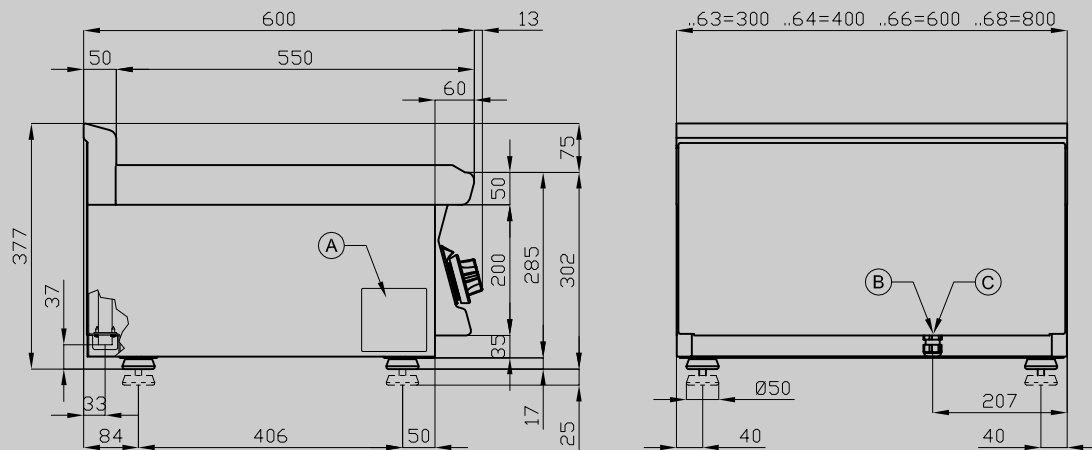

A	Data plate	B	Electrical connection
---	------------	---	-----------------------

**MODEL:** PCCT-66ET  
**DIMENSIONS:** cm. 60x 60x 28h  
**ELECTRIC POWER:** 6 kW  
**VOLTAGE:** 400V~3N / 230V~3 / 230V~  
**FREQUENCY:** 50/60 Hz



**kg:** 26  
**m<sup>3</sup>:** 0.283  
**mm:** 630x690x650

BUY LOTUS BUY ITALY

The pictures are purely representative. The manufacturer reserves the right to modify the technical data and models without previous notice.



LOTUS S.P.A. Via Calmaor, 46  
 31020 San Vendemiano(TV) - Italy  
 Tel. + 39 0438 778020 / 778468  
 Fax + 39 0438 778277  
[www.lotuscookers.it](http://www.lotuscookers.it) - [lotus@lotuscookers.it](mailto:lotus@lotuscookers.it)