

# CFM4-68ET

## 60 MAGICLOTUS ELECTRIC COOKERS



Range threephase - N. 4 plates Multifunction  
electric oven Chamber cm. 64x37x35h,  
temp: 50÷250°C, with 1 grid cm.53x32,5  
GN1/1 - Stainless steel door



Construction - Fabricated using CrNi 18/10 AISI 304 grade Stainless Steel Scotch-Brite Satin polish Finish, incorporating 1mm thick worktop, rounded edges, chromed details and rear splash back. Knobs with waterproof grades IPX5. Model - Professional Electric Cooker with static or multifunction electric oven. Cast Iron round hot plates with steel border seals, seven position switch and temperature limiter. Ceramic glass tops with radiant heat hot plates and warning lights for residual heat, electric oven with 50 - 300degC control. Maintenance - All serviceable parts are accessible by the easy removal of front control panel. Fittings - Appliance is supplied with adjustable feet.

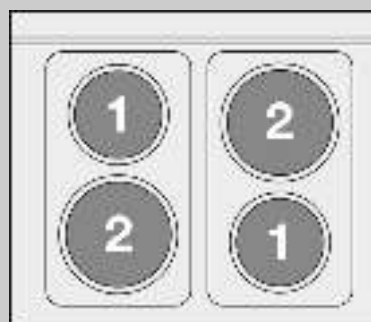

ITALIAN CULINARY ART

The pictures are purely representative. The manufacturer reserves the right to modify the technical data and models without previous notice.

# CFM4-68ET

60 MAGICLOTUS  
ELECTRIC COOKERS

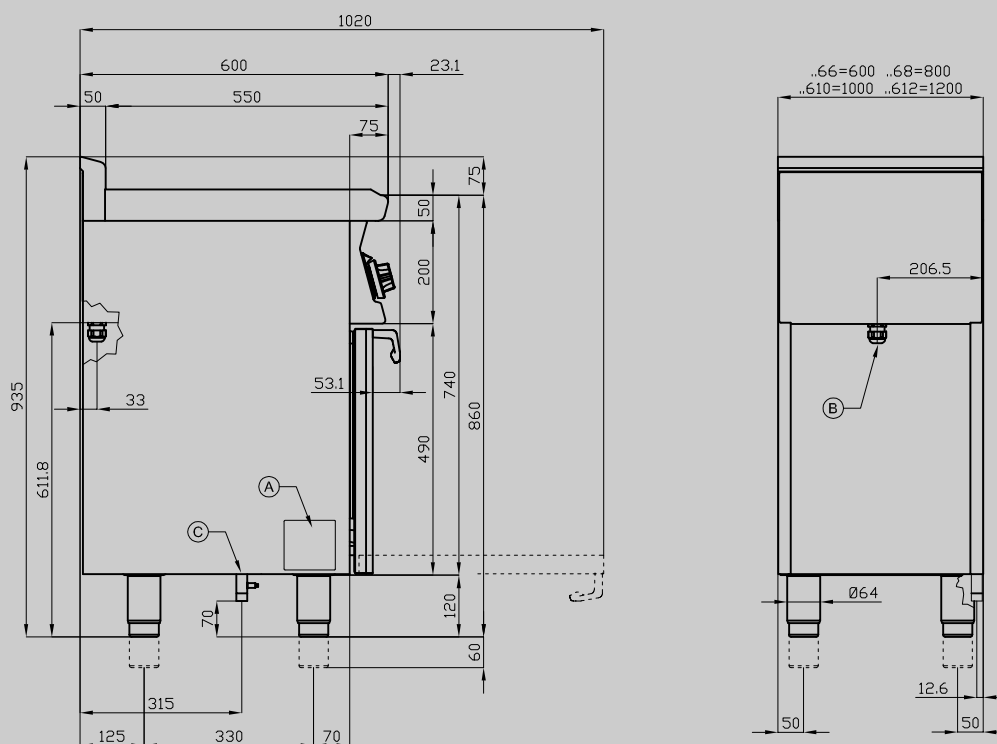

A	Data plate		B	Electrical connection	
---	------------	--	---	-----------------------	--

MODEL: CFM4-68ET  
DIMENSIONS: cm. 80x 60x 90h  
ELECTRIC POWER: 9,05 kW  
VOLTAGE: 400V~3N / 230V~3 / 230V~  
FREQUENCY: 50/60 Hz



kg: 92  
m<sup>3</sup>: 0.617  
mm: 830x670x1110

BUY LOTUS BUY ITALY

The pictures are purely representative. The manufacturer reserves the right to modify the technical data and models without previous notice.



LOTUS S.P.A. Via Calmaor, 46  
31020 San Vendemiano(TV) - Italy  
Tel. + 39 0438 778020 / 778468  
Fax + 39 0438 778277  
www.lotuscookers.it - lotus@lotuscookers.it