

F13-64G

60 MAGICLOTUS GAS FRYERS



Gas fryer 13 lts - Bowl cm. 32,5x31,5x36h - 1 basket cm. 30x27,5x12h. Sieve and lid for pan. - Drip tray with sieve. Production: 10 kg/h



Construction - Fabricated using CrNi 18/10 AISI 304 grade Stainless Steel Scotch-Brite Satin polish Finish, incorporating 1mm thick worktop, rounded edges, chromed details and rear splash back. Knobs with waterproof grades IPX5. **Model** - Professional Gas Fryer on cabinet. With single tank to include both basket and lid, tank filter with basket support. Burner with Piezoelectric ignition and pilot light, thermostatic and thermocouple safety valves. **Maintenance** - All serviceable parts are accessible by the easy removal of front control panel. **Fittings** - Appliance is supplied with both LPG and Natural Gas conversion jets and adjustable feet. Oil filter drain pan included.



ITALIAN CULINARY ART

The pictures are purely representative. The manufacturer reserves the right to modify the technical data and models without previous notice.

F13-64G

60 MAGICLOTUS
GAS FRYERS

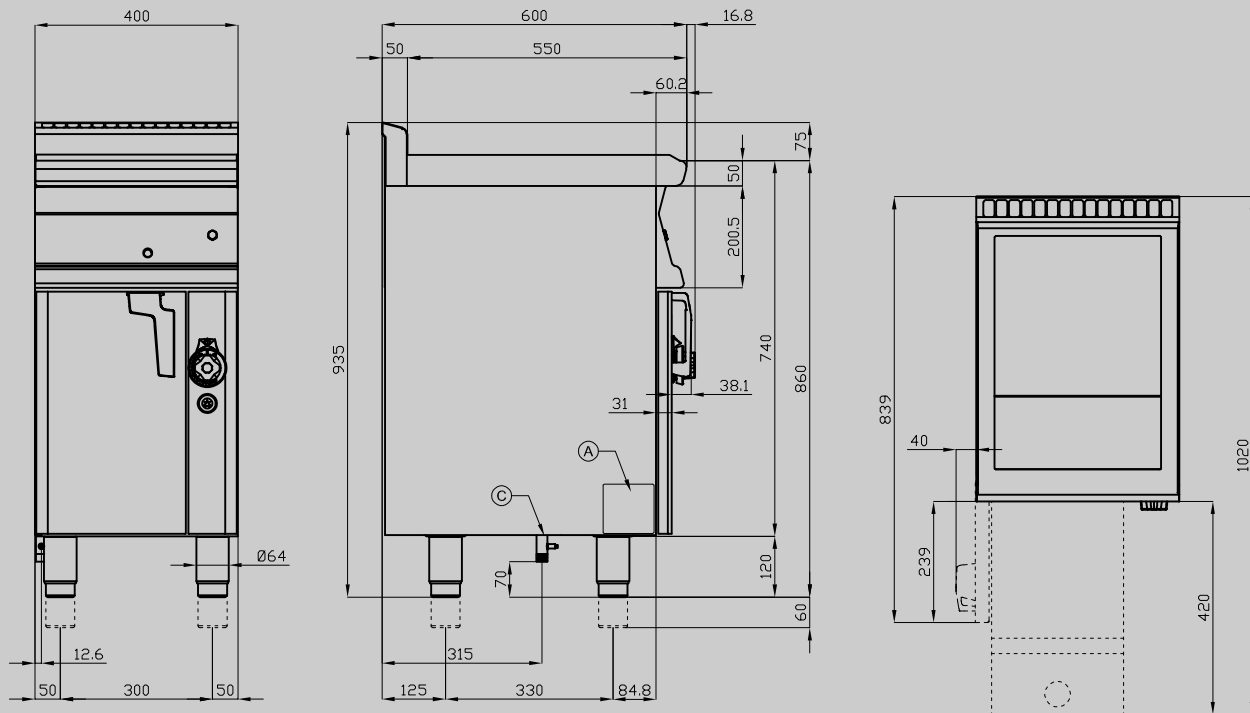

A	Data plate	C	Gas connection	ISO 7-1 1/2" M
---	------------	---	----------------	----------------

MODEL: F13-64G
DIMENSIONS: cm. 40x 60x 90h
GAS POWER: 10,5 kW / 9.020 kcal/h
GAS TYPE: Natural Gas / LPG



kg: 60
m³: 0.368
mm: 430x770x1110

BUY LOTUS BUY ITALY

The pictures are purely representative. The manufacturer reserves the right to modify the technical data and models without previous notice.



LOTUS S.P.A. Via Calmaor, 46
31020 San Vendemiano (TV) - Italy
Tel. + 39 0438 778020 / 778468
Fax + 39 0438 778277
www.lotuscookers.it - lotus@lotuscookers.it