

FTL-2ET

50 SNACK ELECTRIC GRIDDLE

Electric Fry-top smooth griddle, plate cm.
57x41

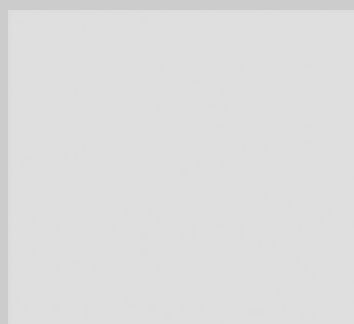
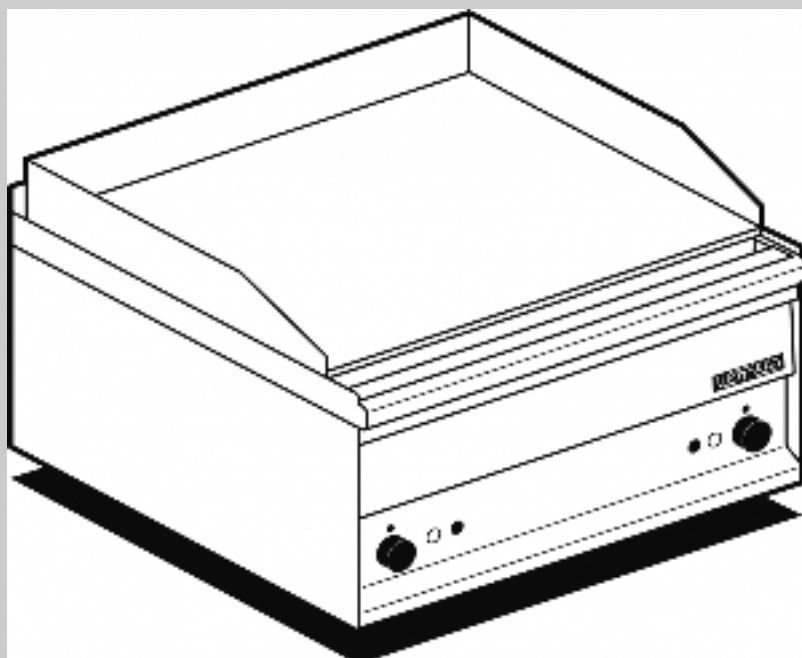

ITALIAN CULINARY ART

The pictures are purely representative. The manufacturer reserves the right to modify the technical data and models without previous notice.

FTL-2ET

50 SNACK

ELECTRIC GRIDDLE

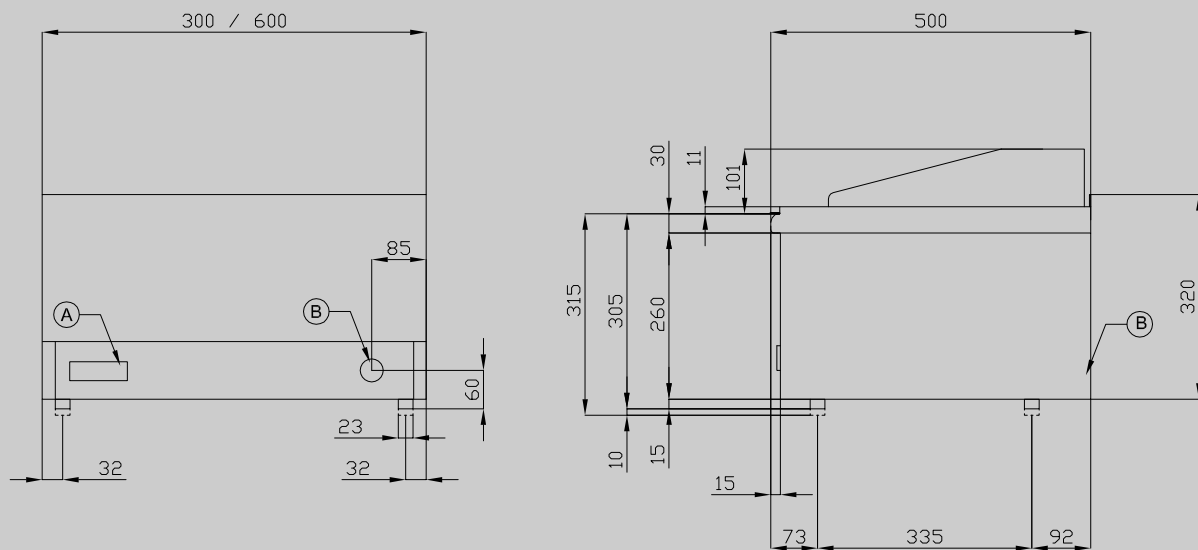

| | | | |
|---|------------|---|-----------------------|
| A | Data plate | B | Electrical connection |
|---|------------|---|-----------------------|

MODEL: FTL-2ET
DIMENSIONS: cm. 60x 50x 29h
ELECTRIC POWER: 6 kW
VOLTAGE: 400V~3N / 230V~3
FREQUENCY: 50/60 Hz



kg: 40
m³: 0.283
mm: 630x690x650

BUY LOTUS BUY ITALY

The pictures are purely representative. The manufacturer reserves the right to modify the technical data and models without previous notice.



LOTUS S.P.A. Via Calmaor, 46
31020 San Vendemiano(TV) - Italy
Tel. + 39 0438 778020 / 778468
Fax + 39 0438 778277
www.lotuscookers.it - lotus@lotuscookers.it