

# FTL-1ET

50 SNACK  
ELECTRIC GRIDDLE

Electric Fry-top smooth griddle, plate cm.  
27x41

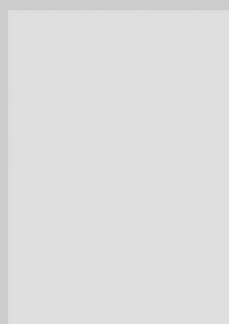

ITALIAN CULINARY ART

The pictures are purely representative. The manufacturer reserves the right to modify the technical data and models without previous notice.

# FTL-1ET

50 SNACK  
ELECTRIC GRIDDLE

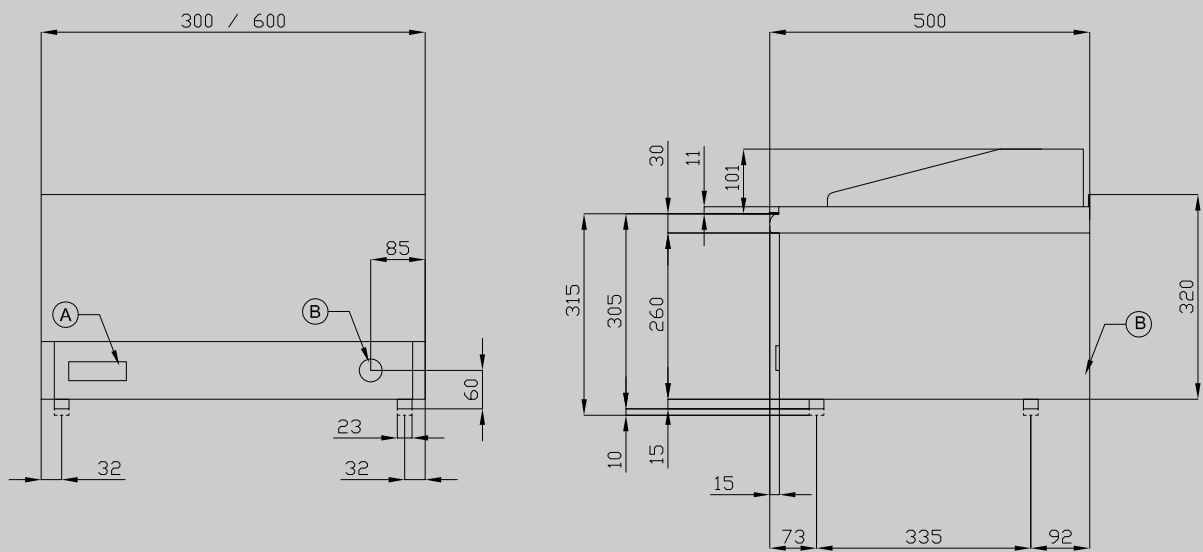

A	Data plate	B	Electrical connection
---	------------	---	-----------------------

MODEL: FTL-1ET  
DIMENSIONS: cm. 30x 50x 29h  
ELECTRIC POWER: 3 kW  
VOLTAGE: 400V~3N / 230V~3  
FREQUENCY: 50/60 Hz



kg: 23  
m<sup>3</sup>: 0.148  
mm: 330x690x650

BUY LOTUS BUY ITALY

The pictures are purely representative. The manufacturer reserves the right to modify the technical data and models without previous notice.



LOTUS S.P.A. Via Calmaor, 46  
31020 San Vendemiano(TV) - Italy  
Tel. + 39 0438 778020 / 778468  
Fax + 39 0438 778277  
www.lotuscookers.it - lotus@lotuscookers.it